



6236B-C 6236AB-C

SOFT SERVE FREEZER

1 Flavor, Countertop, Pasteurization
A: Pump Feed Model



Most **Compact & Powerful**
high capacity countertop model
with **Auto-Pasteurization**
and intelligent control

Auto-Pasteurization

Significantly reduces frequency of cleaning to every 21 days with scheduled daily auto-pasteurization

Digital Control and Display

Microprocessor control provides access to system settings and additional functions. Digital interface displays critical info as system status, temperatures, dispense count, errors, etc.

Operation Logging

Logs every operation and error to provide history and data for easy troubleshooting

Auto Programming

Allows automatic switching of operation modes based on preset schedules

Ideal for any restaurants, convenience stores, dessert stands and delis to serve ice cream and gelato with desire for significant reduction in labor cost of cleaning.

Hopper Agitator

Maintain product consistency and prevent product separation

Defrost for Cleaning

Increases efficiency during cleaning by heating frozen product in cylinder

Direct Drive Transmission

Eliminates consumable moving parts and increases transmission efficiency

Safety Protections

- Low temperature and motor overload shutoffs to protect in the event of cylinder freeze up
- High pressure switch to prevent compressor overheating

Refresh and Revive

Restore perfect consistency automatically to reduce product waste and labor cost while ensuring food safety

Self Closing Valve with Speed Control

Automatically prevents product overflow after dispense; Provides flexibility in dispense rate control



6236B-C/6236AB-C

SOFT SERVE FREEZER

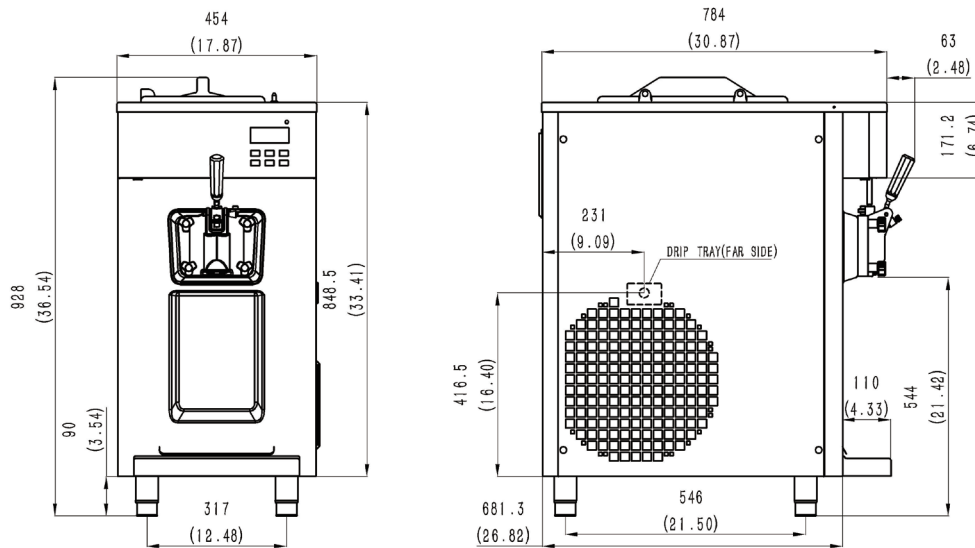

SPECIFICATIONS

Flavors	1
Freezing Cylinders	1x 3.2L / 3.4qt
Mix Hoppers	1x 17L(12L for A)
Output Capacity (80 grams)	420 serves/hr
Clearance Requirements	152mm/6" on left

Weight

	Kg/lb (Gravity)	Kg/lb (Pump)
Net	165/364	170 / 375
Shipping	181/399	186 / 410
Volume	0.47 CBM / 16.62 CBF	

Dimensions

	Net (mm/in)	Shipping (mm/in)
Width	454 / 17.9	500 / 19.7
Depth	681 / 26.8	870 / 34.3
Height	928 / 36.5	1080 / 42.5

Electrical

	MFS	MCA	Power(kW)
380-415/50/3	15	11	2.9
208-230/60/3	20	18	3.1
208-230/50/1	25	16	2.3
208-230/60/1	30	18	2.5

FEATURES

Control System	Single, Digital
Refrigerated Hopper	✓
Hopper Agitator	✓
Temperature Display	✓
Standby Mode	✓
Auto Closing Dispensing Valve	✓
Dispensing Speed Control	✓
Low Mix Indicator Light & Alarm	✓
Low Temperature Protection	✓
Motor Overload Protection	✓
High Pressure Protection	✓
Defrost & Refresh	✓
Soft Start	✓
Direct Drive Pump	✓
Auto-Pasteurization	✓

AVAILABLE OPTIONS

Water Cooled	✓
Top Air Discharge Chute	✓
Cart (Trolley)	✓

• Above specifications are subject to change without notice