



6338B-C 6338AB-C

SOFT SERVE FREEZER

1 Flavor, Floor, Pasteurization
A: Pump Feed Model



Most **Powerful & Versatile**
High capacity 1-flavor floor model
with **Auto-Pasteurization**
and intelligent control

Auto-Pasteurization

Significantly reduces frequency of cleaning to every 21 days with scheduled daily auto-pasteurization

Digital Control and Display

Microprocessor control provides access to system settings and additional functions. Digital interface displays critical info as system status, temperatures, dispense count, errors, etc.

Operation Logging

Logs every operation and error to provide history and data for easy troubleshooting

Auto Programming

Allows automatic switching of operation modes based on preset schedules

Ideal for any restaurants, convenience stores, dessert stands and delis to serve ice cream and gelato but with desire for significant reduction in labor cost of cleaning.

Hopper Agitator

Maintain product consistency and prevent product separation

Defrost for Cleaning

Increases efficiency during cleaning by heating frozen product in cylinder

Direct Drive Transmission

Eliminates consumable moving parts and increases transmission efficiency

Safety Protections

- Low temperature and motor overload shutoffs to protect in the event of cylinder freeze up
- High pressure switch to prevent compressor overheating

Refresh and Revive

Restore perfect consistency automatically to reduce product waste and labor cost while ensuring food safety

Self Closing Valve with Speed Control

Automatically prevents product overflow after dispense; Provides flexibility in dispense rate control



6338B-C/6338AB-C SOFT SERVE FREEZER

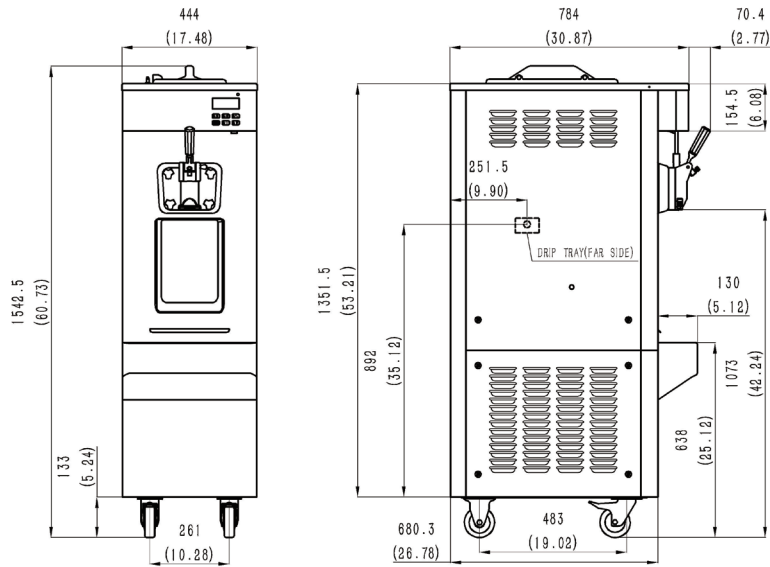

SPECIFICATIONS

Flavors	1
Freezing Cylinders	1 x 3.2L / 3.4qt
Mix Hoppers	1 x 12L (10L for A)
Output Capacity (80 grams)	440 serves/hr
Clearance Requirements	152mm/6" on back

Weight

	Kg/lb (Gravity)	Kg/lb (Pump)
Net	183 / 403	188 / 414
Shipping	193 / 425	198 / 437

Volume 0.75 CBM / 26.53 CBF

Dimensions

Dimensions	Net (mm/in)	Shipping (mm/in)
Width	444 / 17.5	520 / 20.5
Depth	680 / 26.8	860 / 33.9
Height	1543 / 60.7	1680 / 66.1

Electrical

	Power (kW)	Total Amps (A)	Fuse (A)
380-415/50/3	2.9	9	16
208-230/60/3	3.1	12	20

FEATURES

Control System	Single, Digital
Refrigerated Hopper	✓
Hopper Agitator	✓
Temperature Display	✓
Standby Mode	✓
Auto Closing Dispensing Valve	✓
Dispensing Speed Control	✓
Low Mix Indicator Light & Alarm	✓
Low Temperature Protection	✓
Motor Overload Protection	✓
High Pressure Protection	✓
Defrost & Refresh	✓
Soft Start	✓
Direct Drive Pump	✓
Auto-Pasteurization	✓

AVAILABLE OPTIONS

Water Cooled	✓
Top Air Discharge Chute	✓

• Above specifications are subject to change without notice